

[4 marks] Fill in the blanks in the following sentences.

- The unsigned, 3-bit, hexadecimal number 1AB represents  
the unsigned 12-bit binary number 0001 1010 1011  
the unsigned decimal number 427
- The decimal number 683 represents  
the unsigned 12-bit binary number 0010 1010 1011  
the unsigned, 3-bit, hexadecimal number 2AB

[3 marks] Complete the truth table for the circuit diagram below.

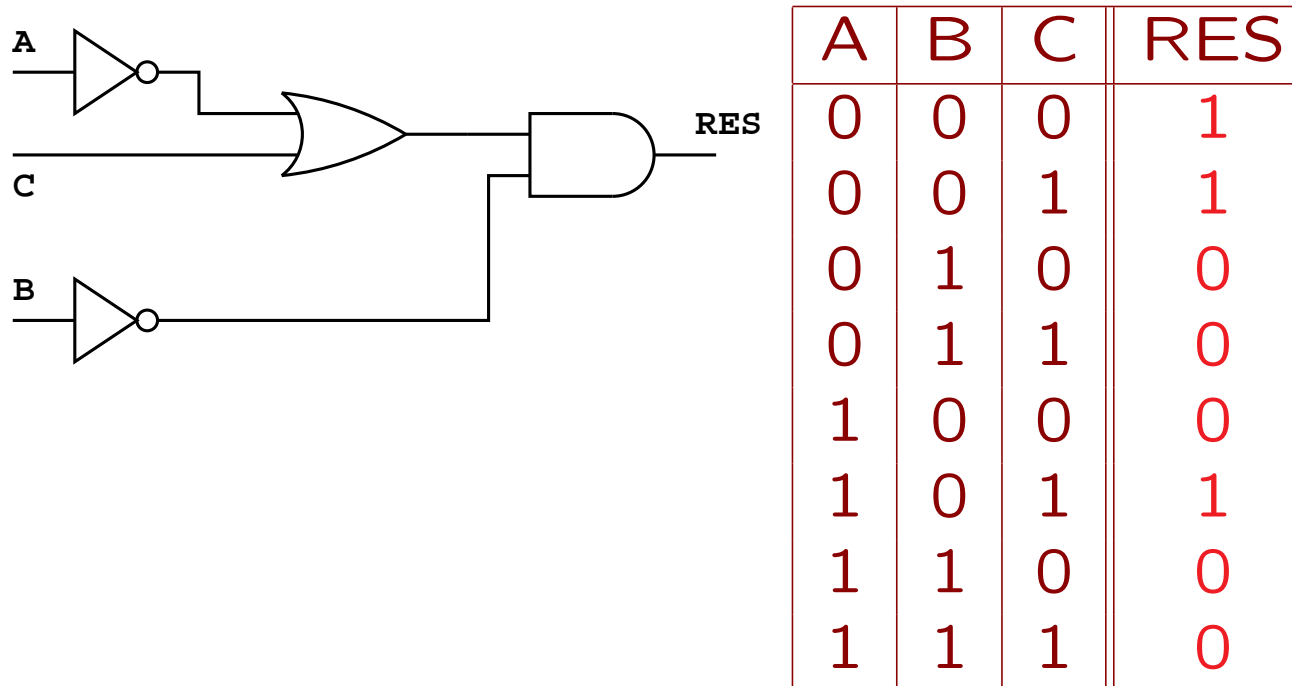

[2 marks] Fill in the blanks in the following sentences.

- The decimal number 4.25 cannot be stored accurately as an 8-bit, signed, floating point, binary number. This is known as a truncation error.
- The decimal number 256 cannot be stored accurately as an 8-bit, signed, two's complement, binary number. This type of error is known as overflow.

[4 marks]

- The decimal number 92 is represented in signed, 8-bit, two's-complement, binary as 0101 1100
- The decimal number -46 is represented in signed, 8-bit, two's-complement, binary as 1101 0010
- The signed, 8-bit, two's-complement, binary number 00110101 represents the decimal number 53
- The signed, 8-bit, two's-complement, binary number 10110101 represents the decimal number -75

[3 marks] Write down whether each of the following statements is either true or false.

In the layered approach to the design of complex systems:

- The assembly language layer is above the machine language layer.

Write *true* or *false*: true

- The electronics layer provides the gates for digital logic.

Write *true* or *false*: true

- Each layer is built upon the resources that the layer below provides.

Write *true* or *false*: true

1. [19 marks in total] Fill in the blanks:

- (a) [1/19] The number of bits in two gigabytes (2 GB) of computer memory (written as a power of 2) is  $2^{34}$
- (b) [2/19] The binary number 101010110100 expressed in hexadecimal is AB4
- (c) [2/19] The hexadecimal number A09D expressed in 16-bit binary is 1010 0000 1001 1101
- (d) [2/19] The decimal number 11.375 expressed in 8-bit binary (using a radix point after the 4<sup>th</sup> bit) is 1011.0110
- (e) [2/19] The binary number 1110.0100 expressed in decimal is 14.25

(f) [2/19] The 8-bit two's complement binary number 10101010 expressed in decimal is -86

*Show your working steps here:*

Sign is 1 so number is negative.

Flip all bits to get 01010101.

Add 1 to get 01010110.

(g) [2/19] The decimal number -127 expressed in two's complement 8-bit binary is 10000001

*Show your working steps here:*

+127 is 01111111.

Flip all bits to get 10000000.

Add 1 to get 10000001.

(h) The remainder of this question deals with converting floating point numbers from binary to decimal and vice versa. The representation of such numbers in binary involves 8 bits where the first bit is the sign bit, the next three bits represent the exponent (using excess four notation) and the final four bits represent the mantissa.

i [3/19] The binary number 11101110 expressed in decimal is -3.5

*show your working steps here:*

Mantissa is .1110.

Exponent is 110 = +2.

$.1110^2 = 11.10 = 3.5$ .

Sign is negative.

- ii [3/19] The decimal number  $-5/16$  expressed in binary is 10111010

*show your working steps here:*

Sign is negative.

$5/16$  is  $0.0101$ .

Mantissa is  $.1010$ .

Exponent is  $-1 = 011$ .

[3/18] Complete the truth table for the expression.

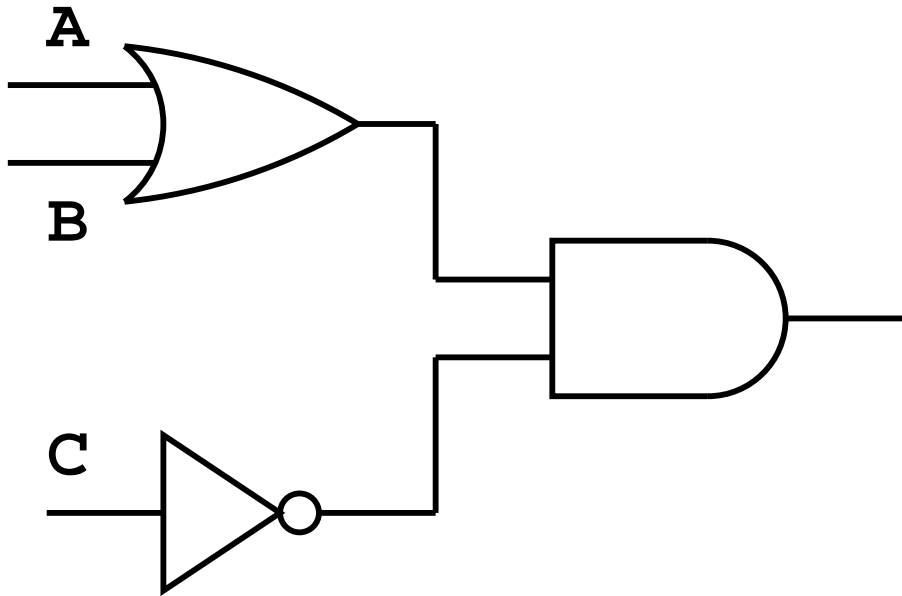

| A | B | C | Output |
|---|---|---|--------|
| 0 | 0 | 0 | 0      |
| 0 | 0 | 1 | 0      |
| 0 | 1 | 0 | 1      |
| 0 | 1 | 1 | 0      |
| 1 | 0 | 0 | 1      |
| 1 | 0 | 1 | 0      |
| 1 | 1 | 0 | 1      |
| 1 | 1 | 1 | 0      |