

[4 marks] Fill in the blanks in the following sentences.

- The unsigned, 3-bit, hexadecimal number 1AB represents
the unsigned 12-bit binary number 0001 1010 1011
the unsigned decimal number 427
- The decimal number 683 represents
the unsigned 12-bit binary number 0010 1010 1011
the unsigned, 3-bit, hexadecimal number 2AB

[3 marks] Complete the truth table for the circuit diagram below.

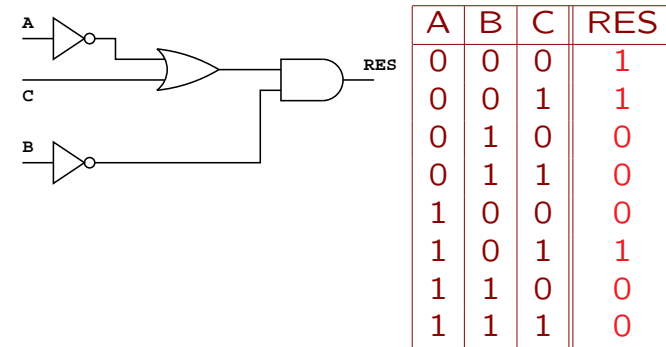

[2 marks] Fill in the blanks in the following sentences.

- The decimal number 4.25 cannot be stored accurately as an 8-bit, signed, floating point, binary number. This is known as a truncation error.
- The decimal number 256 cannot be stored accurately as an 8-bit, signed, two's complement, binary number. This type of error is known as overflow.

[4 marks]

- The decimal number 92 is represented in signed, 8-bit, two's-complement, binary as 0101 1100
- The decimal number -46 is represented in signed, 8-bit, two's-complement, binary as 1101 0010
- The signed, 8-bit, two's-complement, binary number 00110101 represents the decimal number 53
- The signed, 8-bit, two's-complement, binary number 10110101 represents the decimal number -75

[3 marks] Write down whether each of the following statements is either true or false.

In the layered approach to the design of complex systems:

- The assembly language layer is above the machine language layer.

Write *true* or *false*: true

- The electronics layer provides the gates for digital logic.

Write *true* or *false*: true

- Each layer is built upon the resources that the layer below provides.

Write *true* or *false*: true

1. [19 marks in total] Fill in the blanks:

(a) [1/19] The number of bits in two gigabytes (2 GB) of computer memory (written as a power of 2) is 2^{34}

(b) [2/19] The binary number 101010110100 expressed in hexadecimal is AB4

(c) [2/19] The hexadecimal number A09D expressed in 16-bit binary is 1010 0000 1001 1101

(d) [2/19] The decimal number 11.375 expressed in 8-bit binary (using a radix point after the 4th bit) is 1011.0110

(e) [2/19] The binary number 1110.0100 expressed in decimal is 14.25

(f) [2/19] The 8-bit two's complement binary number 10101010 expressed in decimal is -86

Show your working steps here:

Sign is 1 so number is negative.

Flip all bits to get 01010101.

Add 1 to get 01010110.

(g) [2/19] The decimal number -127 expressed in two's complement 8-bit binary is 10000001

Show your working steps here:

+127 is 01111111.

Flip all bits to get 10000000.

Add 1 to get 10000001.

(h) The remainder of this question deals with converting floating point numbers from binary to decimal and vice versa. The representation of such numbers in binary involves 8 bits where the first bit is the sign bit, the next three bits represent the exponent (using excess four notation) and the final four bits represent the mantissa.

i [3/19] The binary number 11101110 expressed in decimal is -3.5

show your working steps here:

Mantissa is .1110.

Exponent is 110 = +2.

$.1110^2 = 11.10 = 3.5$.

Sign is negative.

ii [3/19] The decimal number $-5/16$ expressed in binary is 10111010

show your working steps here:

Sign is negative.

$5/16$ is 0.0101.

Mantissa is .1010.

Exponent is $-1 = 011$.

[3/18] Complete the truth table for the expression.

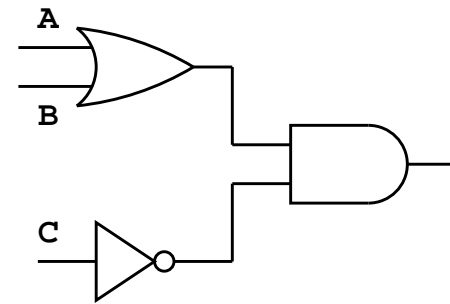

A	B	C	Output
0	0	0	0
0	0	1	0
0	1	0	1
0	1	1	0
1	0	0	1
1	0	1	0
1	1	0	1
1	1	1	0