

Extensions of Relational DBMSs (refer to the readings)

- To accurately model data semantics and data relationships that arise frequently in typical database applications.
- No support for behavioural semantics.

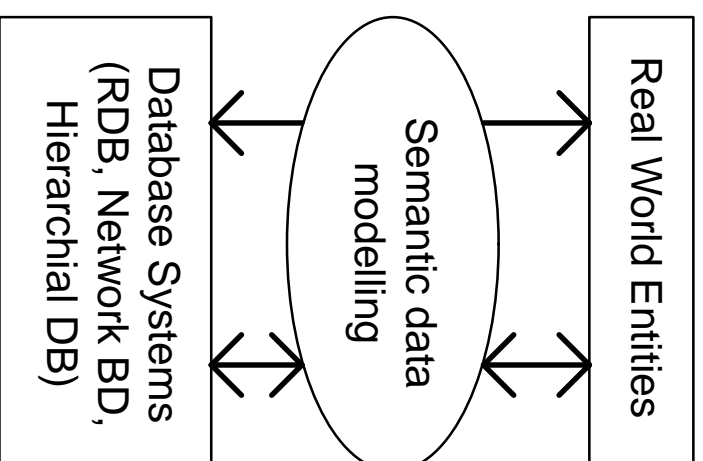

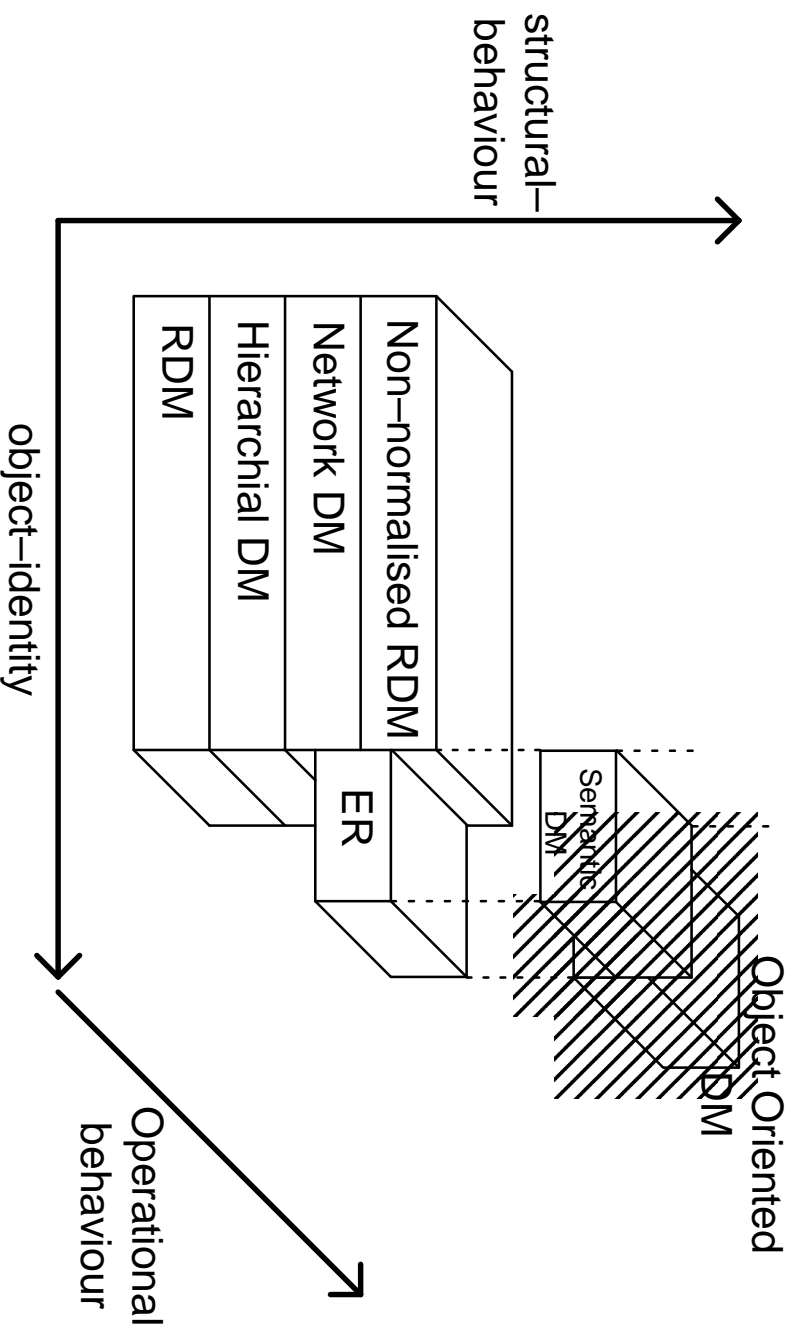

6.1 Modelling Generalization and Aggregation in RDM.

John Miles Smith and Diane C.P. Smith, 1979

Abstraction is a model in which details are deliberately omitted.

- The objective is to allow users to heed details which are relevant to the application and ignore other details.
- Aggregation is an abstraction which turns a relationship between objects into an aggregate object.
- Generalisation is an abstraction which turns a class of objects into a generic object.

A graphical notion for the **generic structure**.

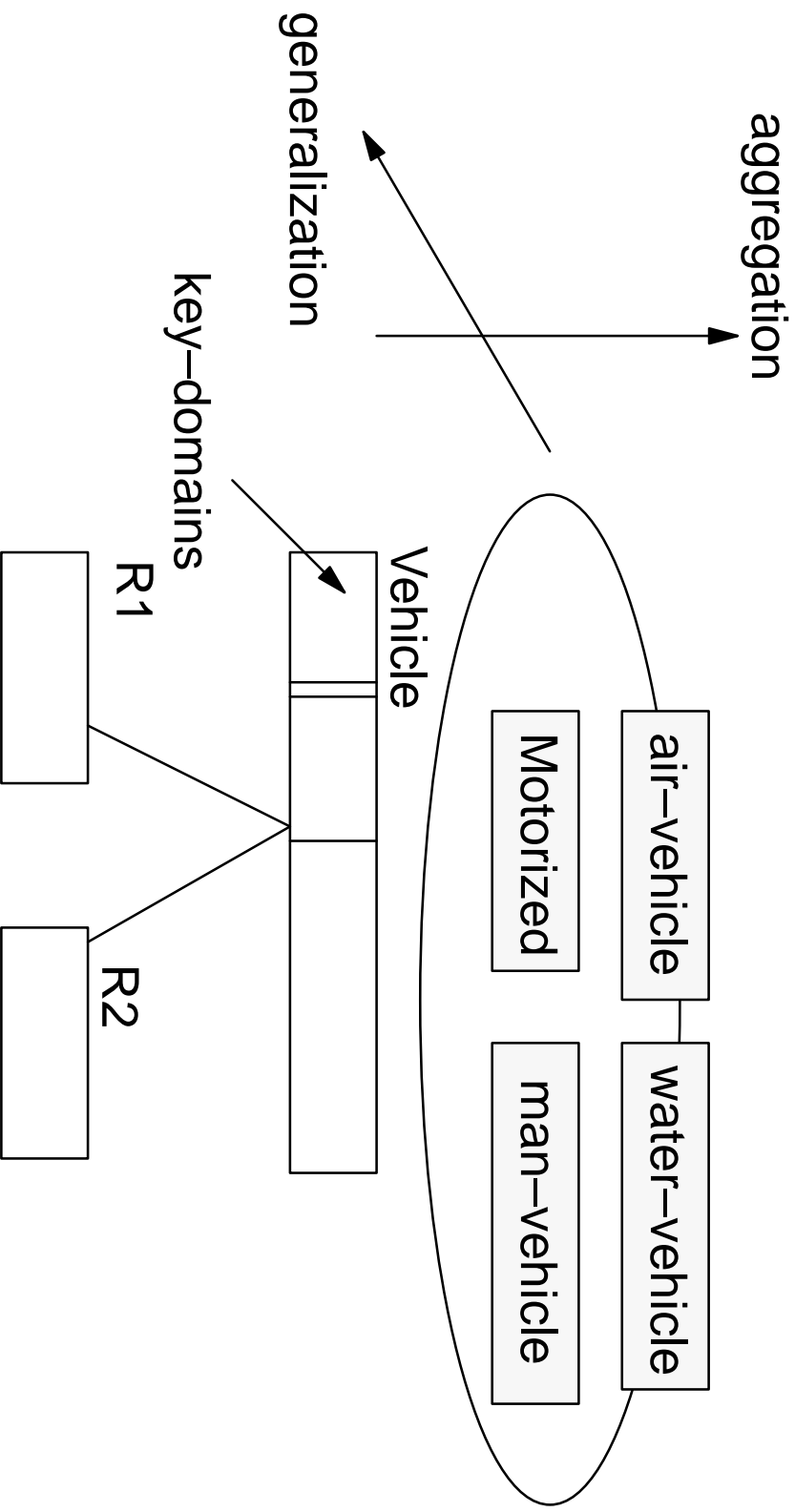

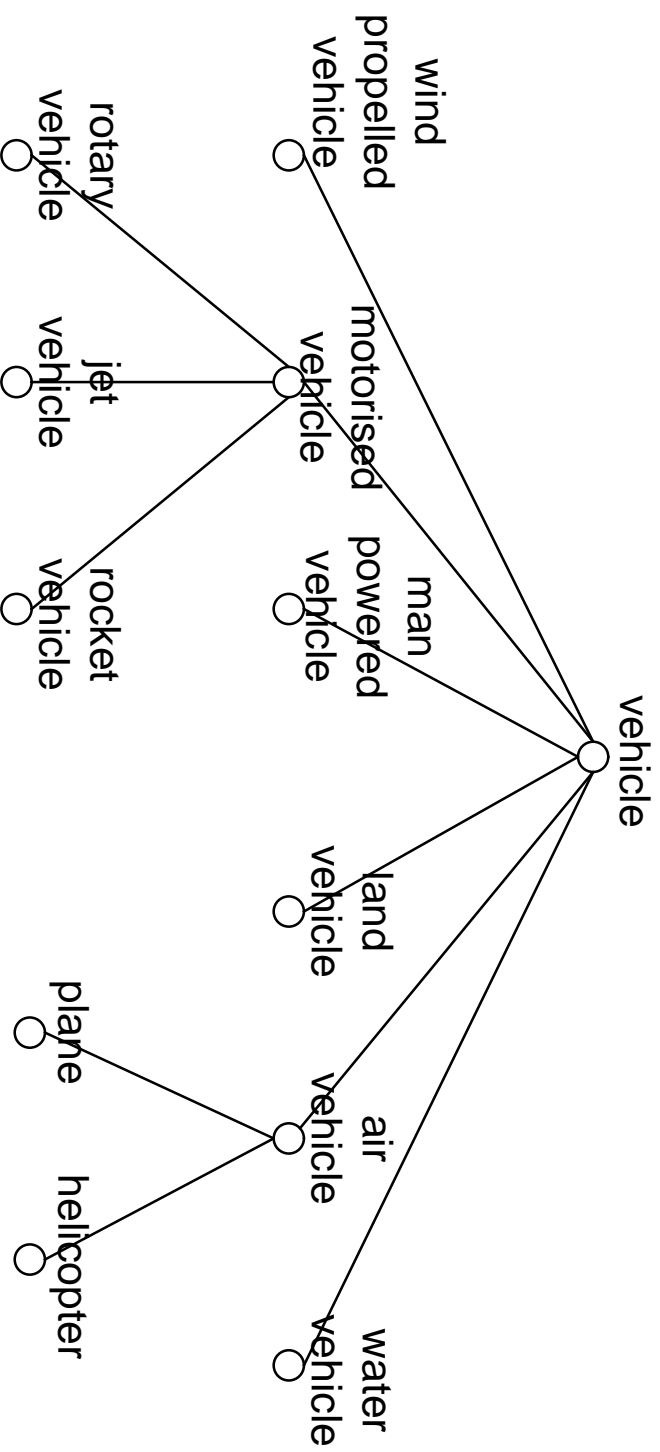

vehicle :

<i>iden. num.</i>	<i>Manufacturer</i>	<i>Price</i>	<i>Weight</i>	<i>Medium category</i>	<i>Propulsion category</i>
V1	Mazda	65.4	10.5	land vehicle	motorised vehicle.
V2	Schwin	3.5	0.1	land vehicle	man powered vehicle
V3	Boeing	7,900	840	air vehicle	motorised vehicle
V4	Aqua Co.	12.2	1.9	water vehicle	wind propelled vehicle
V5	Gyro Inc.	650	150	air vehicle	motorised vehicle

motorised vehicle :

<i>iden. num.</i>	<i>Manufacturer</i>	<i>Price</i>	<i>Weight</i>	<i>Hors power</i>	<i>fuel capacity</i>	<i>Motor category</i>
V1	Mazda	65.4	10.5	150	300	rotary vehicle
V3	Boeing	7,900	840	9600	2600	jet vehicle
V5	Gyro Inc.	650	150	1500	2000	rotary vehicle

air vehicle :

<i>iden. num.</i>	<i>Manufacturer</i>	<i>Price</i>	<i>Weight</i>	<i>Max Altitude</i>	<i>Take-off distance</i>	<i>Lift category</i>
V3	Boeing	7,900	840	30	1000	plane
V5	Gyro Inc.	650	150	5.6	0	helicopter

Discussion

- Difference between Database Abstraction and Normal Forms
 - Normal forms capture some notion of “basic aggregate object” in term of the concept of functional dependency.
 - Normal forms do not address generalization.
 - Normal forms are not able to distinguish what is, or is not, an aggregate object.
- Replication of data when mapped into the RDB.
- No behavioural object orientation.
- The semantics of the underlying object structure is not easily seen.
- Costly update operations to guarantee the consistency of the replicated information.

6.2 *Molecular Objects*, Batory and Buchmann, 1984

- Extend the work on aggregation by Smith and Smith. Smith and Smith's aggregation is an abstraction of a single relationship into a higher-level entity.
- A molecular object is formed by molecular aggregation.
- A molecular aggregation is an abstraction of a set of entities and their relationships into a higher-level entity.
- Molecular object is to model complex, heterogeneously structured entities that are composed of a variety of subentities.

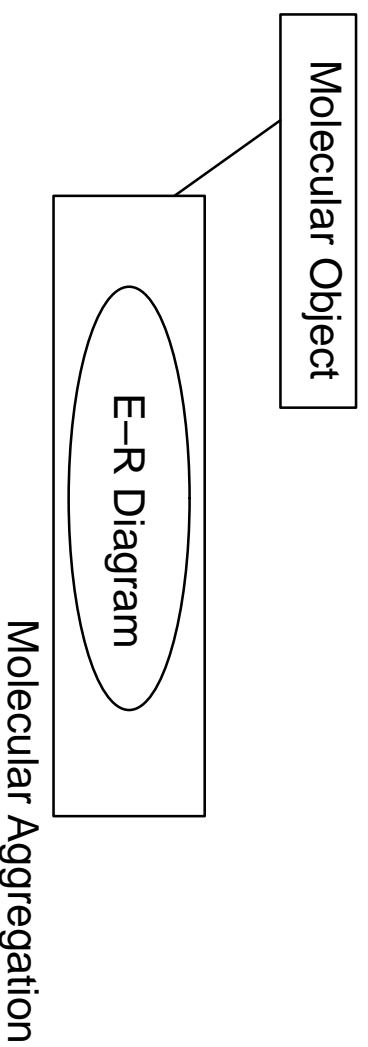

Example:

Consider a catalog of data structure diagrams. On each page of the catalog is a data structure diagram. Each diagram is identified by a catalog number and is explained by a catalog description.

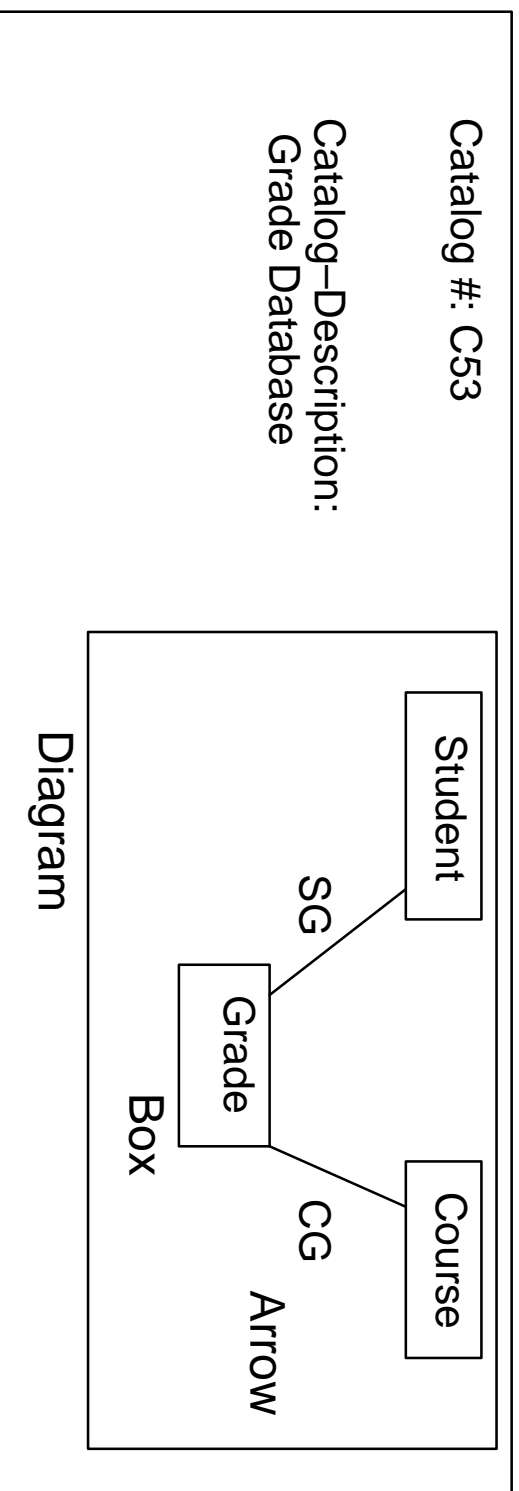

Data Structure Diagram

E-R Diagram:

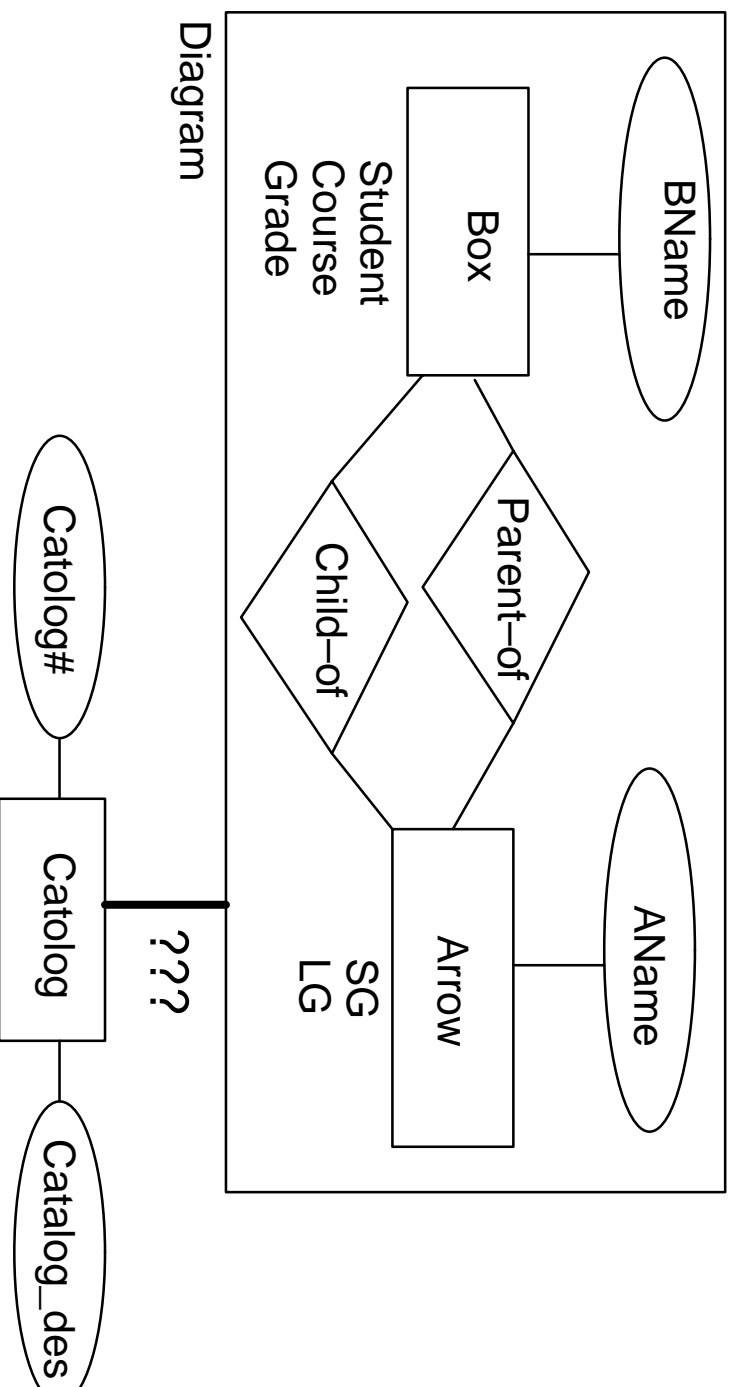

There is no DSD(Data Structure Diagram). The C53 entity and its relationship to the other tuples are not represented.

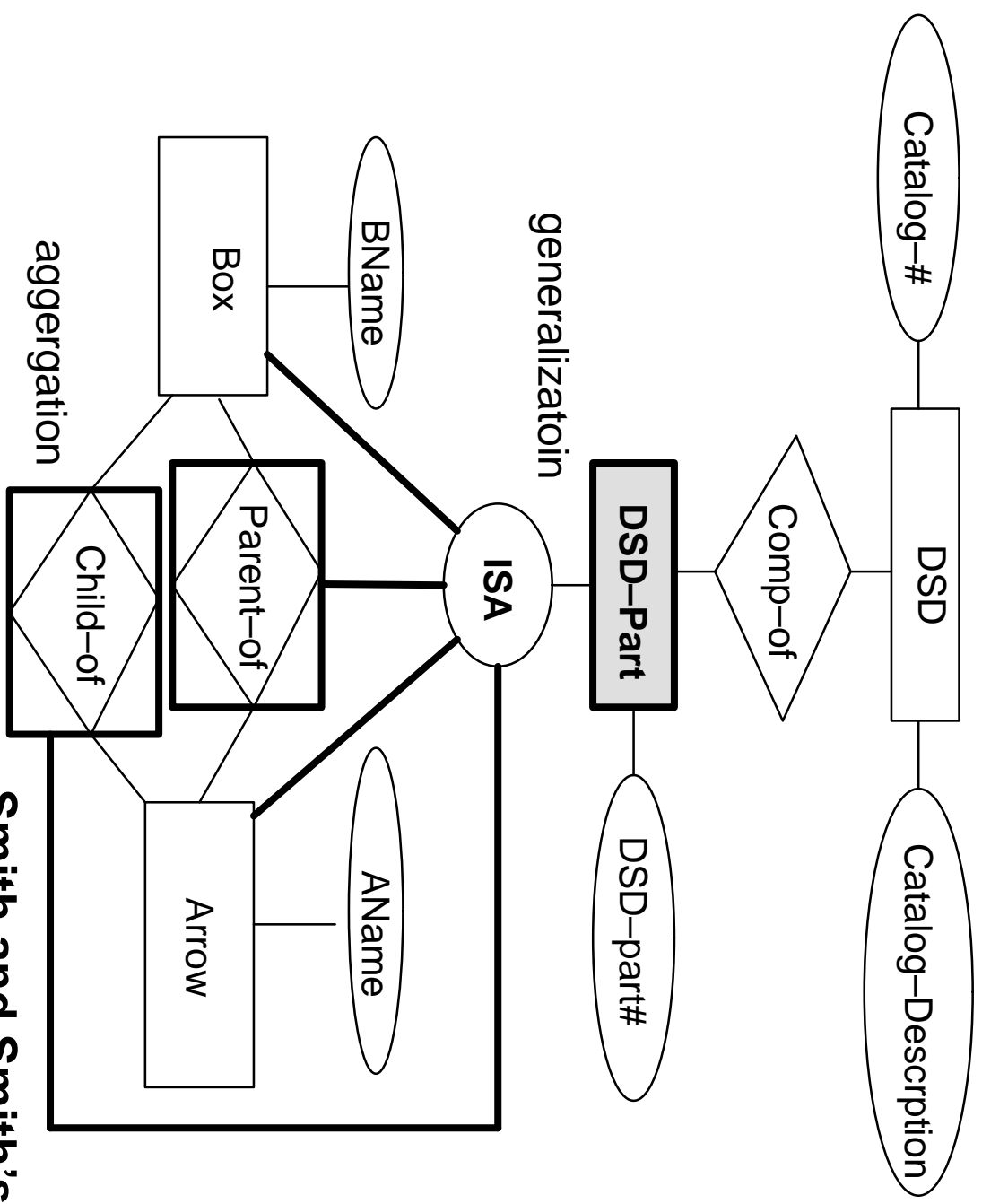

Smith and Smith's Approach

Molecular Object Approach

Molecular Object

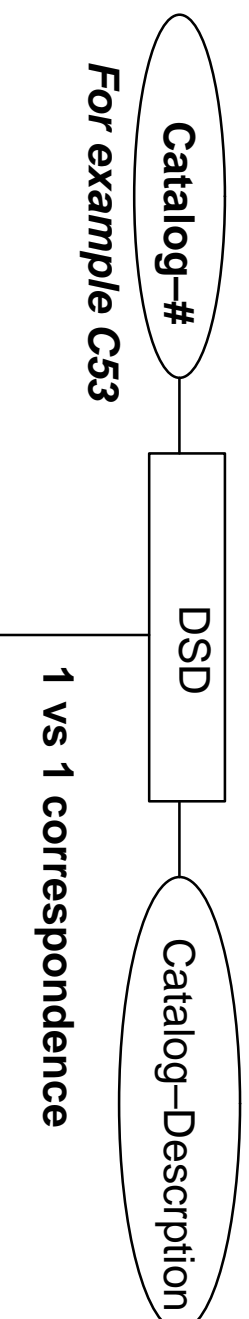

For example C53

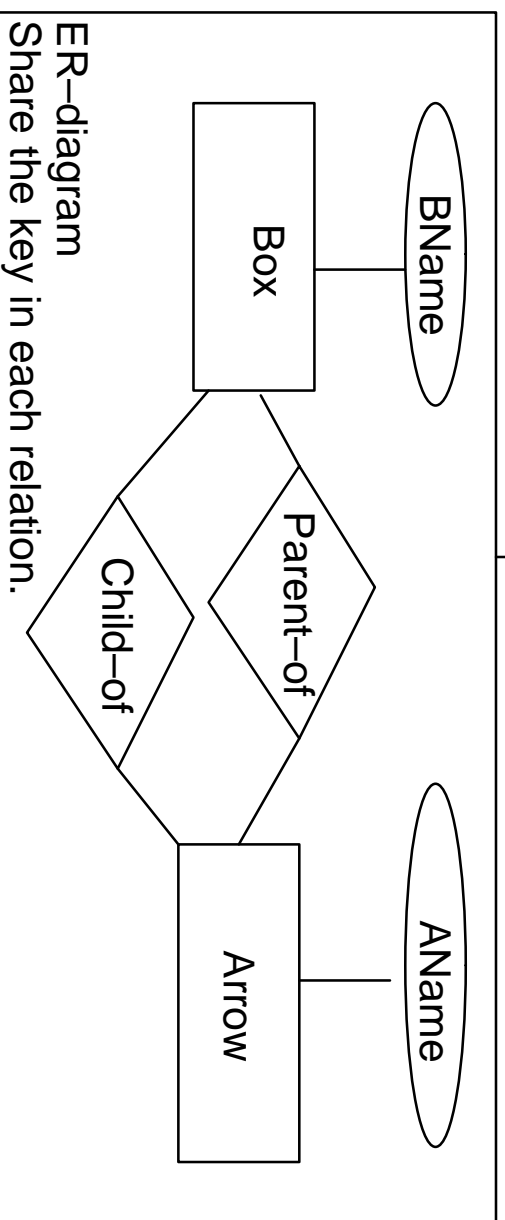

Molecular Aggregation

Each relation must have "Catalog-#" as a part of its key.

- Molecular objects are classified into four categories.
 - Disjoint, nonrecursive; the example above.
 - Nondisjoint, nonrecursive; the example above + sharing.
 - Disjoint, recursive; binary trees.
 - Nondisjoint, recursive; Two lists share a sublist.

Discussion of Molecular Objects

- As a methodology to classify object types of an application.
- No RDBMS extension achieves an adequate support of all four classes of molecular objects.

6.3 A General Reference Mechanism

```
EMP (name, salary-history, hobbies,  
     dept, age, bonus)  
DEPT (dname, floor)  
SALARY (name, date, pay-rate)  
SOFTBALL (name, position, average)  
MUSIC (name, instrument, level)  
RACING (name, auto, circuit)
```

EMP

name	salary–history	hobbies	dept	age	bonus
<i>Fred</i>	range of s is SALARY retrieve(s.all) where s.name = "Fred"	range of m is MUSIC retrieve(m.all) where m.name ="Fred"	range of d is DEPT retrieve(d.dname) where d.name = "toy"	25	10

MUSIC

name	instrument	level
Fred	piano	novice

RACING

name	auto	circuit
Fred	formula Ford	SCCA

```
range of e is EMP
retrieve(e.hobbies.instrument)
where e.name = "Fred" and
      e.hobbies.level = "novice"
```

“QUEL as a Datatype” provides an extremely general referencing mechanism within the context of the relational model. However, the generality has to be paid for in terms of lack of type safety.

6.4 Abstract Data Types in RDM

- Define ADT

```
define ADT (  
    typename = "graph" ,  
    bytein = 128 ,  
    byteout = 128 ,  
    inputfunc = "to_internal_graph" ,  
    outputfunc = "to_external_graph" ,  
    filename = "/usr/ingres/.../graph" )
```

- Define ADT operations

```
define adtop (  
    opname = "eq" ,  
    funcname = "graph_eq" ,  
    filename = "/usr/ingres/.../graph_eq" ,  
    result = boolean ,  
    arg1 = ADT:graph ,  
    arg2 = ADT:graph )
```

6.5 Hierarchical Object Support in XSQL

- A complex object constitutes an entity that is composed hierarchically of several subentities that themselves may be composed of subentities.
- Three system domains: Surrogates, Component-Of, Reference.

6.6 Nested Relational Model

S-ID	Name	Units	
		Unit-ID	Name
1234567	William Smith	c43	User Interface
		c18	Software Eng.